

**C-SERIES HYDRAULIC EXCAVATORS
CX210C | CX250C**

CASE
CONSTRUCTION



**QUALITY
YOU CAN TRUST**

www.casece.com
**EXPERTS FOR THE REAL WORLD
SINCE 1842**

MAIN REASONS TO CHOOSE THE C-SERIES



HIGH EFFICIENCY

A combination of engine technology and Advanced Hydraulic System grants 10% of fuel economy. With the 5 Energy Saving Controls, Isuzu Tier IV Interim engine and the new ECO gauge function.



HIGH RELIABILITY

- New HD boom and arm design: more robust and reinforced to optimize durability and performance;
- Re-designed attachment for more durability: less maintenance cost, higher resale value.

With the CASE top manufacturing quality.



HIGH PRECISION AND CONTROLLABILITY

- Advanced Hydraulic System;
- Unique pump torque control system;
- Advanced energy management with innovative fuel saving functions;
- 3 available power modes to match customers needs.





MAXIMUM COMFORT

Estra large cab: 7% more space Vs previous model.
Low noise and vibrations.
Ergonomic workstation.
Real time parameters monitoring.
Fully adjustable seat/joysticks and brand new LCD cluster.



SAFETY FIRST

- A full range of optional front guards;
 - Superior visibility;
 - Standard Rear view camera.
- With Standard Rops cab and Fops, level II certified.



HIGH VERSATILITY

- Standard Flow Regulation;
 - Up to 10 attachments settings can be memorized;
- Optional Clamshell circuit;
- MULTI-FITS (safe, automatic and universal).



LOW TOTAL COST OF OWNERSHIP AND REPAIR COST

- Cab filters access form
- Standard EMS (Easy Maintenance System) bushings
- Long maintenance intervals
- Low effort for serviceability
- Good service access, onboard diagnosis

C- SERIES

HYDRAULIC EXCAVATORS



POWERFUL AND FUEL EFFICIENT ENGINE

The C-Series Hydraulic Excavators are powered by Tier 4 Interim - certified Isuzu Engine with CEGR (cooled exhaust gas recirculation) and one-piece diesel particle difusor (DPD) that burns cleaner while delivering superior horsepower.

The combination of engine technology and Advanced Hydraulic System grants **10% of fuel economy**.

Automatic self-regeneration of the diesel particulate diffusor (DPD) ensures no loss of productivity, while low engine rpm, improved hydraulic pump control and five new energy saving systems boost fuel economy by up to 10%.

A green economy gauge can be activated in the cab to inform the operator of the most economical settings for the machine, reporting fuel consumption in real-time.



ADVANCED ENERGY MANAGEMENT

- **POWER SAVE:** the pump discharge pressure when the machine is at rest.
- **PUMP TORQUE CONTROL:** prevents drop in engine rpm when lifting heavy loads.

Less fuel consumption and effective energy usage thanks to the **5 ENERGY SAVING FUNCTIONS:**

- **BEC - Boom Economy Control:** it increases the fuel efficiency during the lowering of the boom and swing operations;
- **AEC - Automatic Economy Control:** it reduces the rpm when the joysticks are in neutral position;
- **SRC - Swing Relief Control:** the pump sends a small amount of oil at the very beginning of the slewing operations;
- **SSC - Spool Stroke Control:** automatic pressure adjustment during digging and leveling;
- **AES - Auto Energy Safe:** Auto Idle and Idle Shut Down.





HIGH RELIABILITY

Improved design for durable performances

The new boom and arm are Heavy Duty, more robust and reinforced in the more stressed areas, optimizing the durability and the performances at the same time: the boom is average 8% lighter than the previous series.

HD booms and arms are standard, to grant the maximum reliability also in the toughest applications.

Increased productivity: extra lifting capacity thanks to the front attachment optimization;

Maximum efficiency: lighter, but stronger front attachment (more lifting, less fuel consumption);

Higher resale value: re-designed attachment for more durability and less maintenance cost.

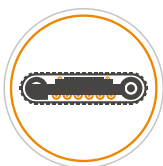

ROBUSTNESS

The C-Series Hydraulic Excavators undercarriage is made with high quality components, with thick structural plates in the areas where components required and higher level of resistance.

Heavy duty solutions

The Heavy duty undercarriage ensures safe and productive performance on all terrains.

- X-chassis design to grant a better weight distribution and a superior stability;
- Heavy duty and high quality material;
- Heavy duty travel engine protection;
- Extra heavy duty carrier roller brackets.

C- SERIES HYDRAULIC EXCAVATORS



COMFORT AND SAFETY

- Superior wide and roomy cab with ample legroom.
- New cushioning system to lower noise and vibration levels for the operator's ultimate comfort.
- Totally adjustable workstation with fully reclinable air –suspensioned seat.
- Air conditioning system with 25% more airflow and 6% better performances.



OUTSTANDING VISIBILITY

- Wider glazed surface with single piece side window.
- New 7" LCD cluster for a more secure and safe working environment and to constant monitor the main machine parameters.



COMFORT RULES FIRST CLASS CAB AND SEAT

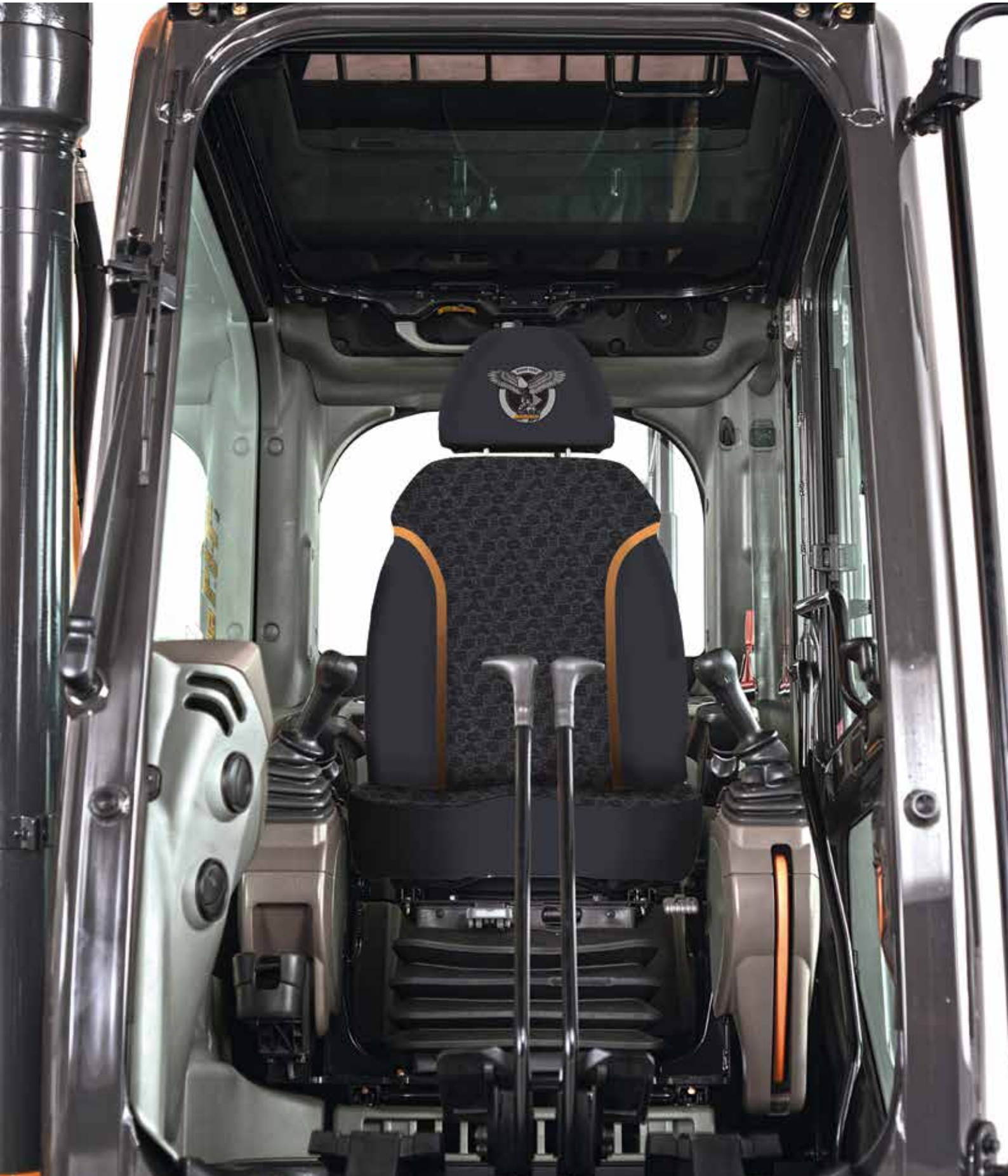



THE CASE DEALER: YOUR PROFESSIONAL PARTNER

Your success starts with world-class Case machinery and attachments.

Your Case dealer will help you work smarter and faster by selecting equipment that delivers performance and operator comfort.

Your dealer has the knowledge and experience necessary to help you choose the right attachments so you can...

- **Work faster and extend equipment life.**
- **Increase machine utilization.**
- **Increase your capabilities.**

Let your Case dealer service your machine on the jobsite.

You'll be back on the job faster.

Advantages include...

- **Responsive job site service to keep your equipment running.**
- **Increase machine uptime.**
- **Certified service staff and improved parts availability.**



PARTS

When you're looking for superior parts options to maximize the performance and lower the operating costs of your Case machinery, turn to CNH Industrial Genuine Parts to keep you equipped for success.

CNH Industrial Genuine Parts fit better, install faster and last longer and in an industry where "high impact" and "heavy lifting" are the norm, the smallest mechanical differences can lead to big problems.

CNH Industrial Genuine Parts from Case are manufactured from superior materials and specifically designed for Case construction equipment to continually and reliably withstand the punishment of everyday construction. So steer clear of mechanical problems and future breakdowns, by choosing CNH Industrial Genuine Parts from Case. They're the only parts that are field-tested and proven to keep your Case equipment performing its best.

SERVICE. RELY ON CASE TO DELIVER FOR YOU

Your commitment to your operation is evident every day, but that doesn't minimize the enormous pressure you face to reduce operating costs and improve productivity. So when you're on the job, make sure you have top-notch service and support of Case behind you every step of the way.

With our factory trained technicians, you can ensure that top-notch service professionals are working on your maintenance needs, so you can focus on your business and the big job challenges ahead, not on the tasks of servicing your equipment.

With your Case Service, you get more than mere oil changes. A Case Service ensures your Case equipment receives a thorough service that meets all requirements of its service schedules and properly maintains it for the day-in, day-out punishment of construction work.

Don't give another thought to time-consuming maintenance tasks. Simply rest easy and make certain that your service needs are taken care of by a Case factory trained technician.

When the unexpected occurs, you need to know your equipment is protected.

At Case Construction we understand the importance of your machinery being in good working order when it counts.

ProCover is designed to help keep your equipment working well beyond the manufacturer's base warranty period while taking away the concerns of the cost and inconvenience of mechanical failure.

WHAT ARE THE ADVANTAGES OF PROCOVER?

PEACE OF MIND

Provides protection beyond the Manufacturer's Base Warranty Period.

FLEXIBLE OPTIONS

Plans can be customised to meet individual needs.

DEPENDABLE SERVICE

Eligible repairs completed by an authorised Case Construction Dealership and their trained service technician's using genuine OEM parts & lubricants.

TRANSFERABLE PROTECTION

New Equipment Plans may be transferred to a new owner at no charge

COVERAGE

- **STANDARD PROTECTION PLAN** **3 Years / 5000 Hours**
Additional years/hours can be purchased.
Please contact your local Case Construction dealer for further information.

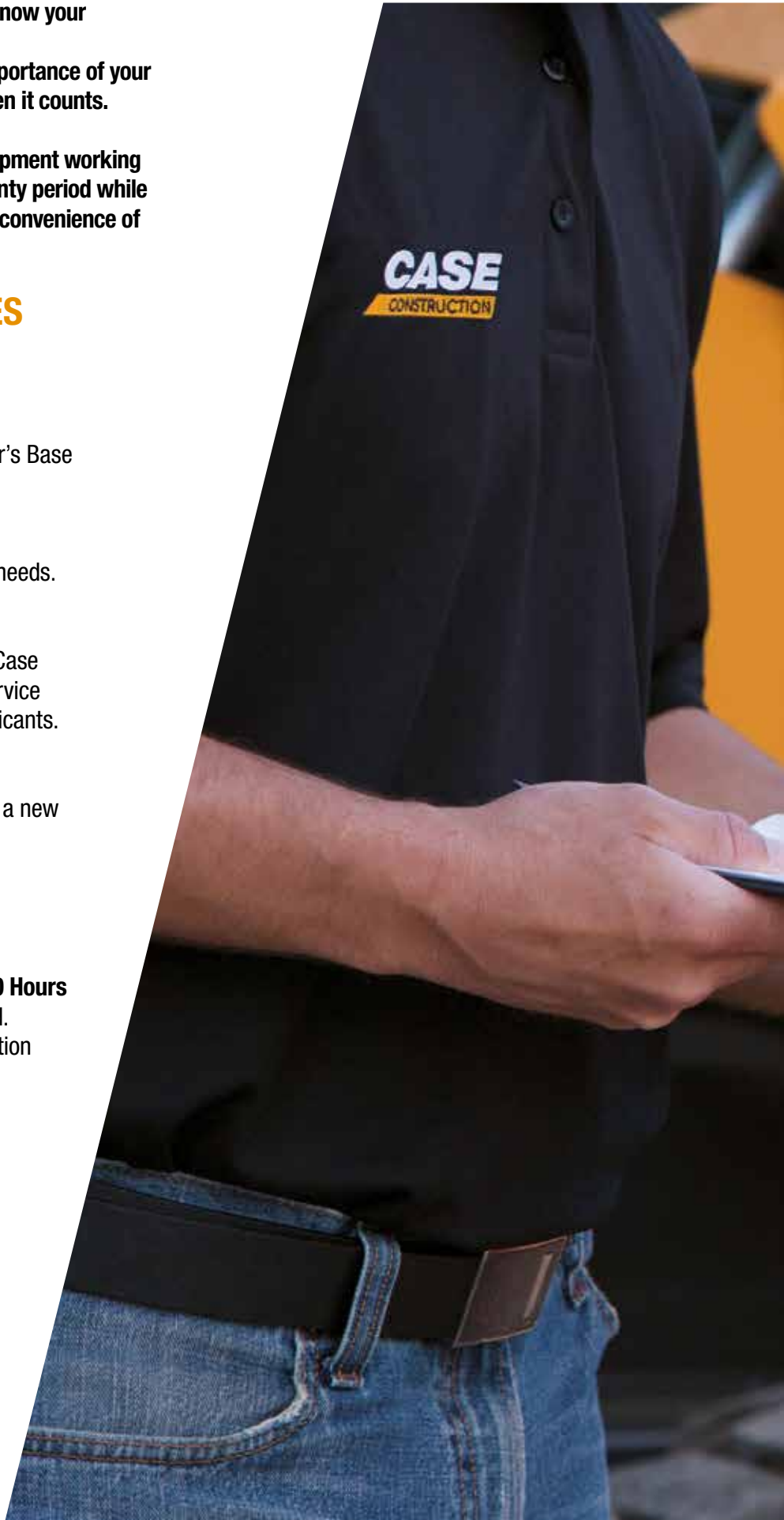

CX210C

ENGINE

Model _____ ISUZU AM-4HK1X
 Type _____ Water-cooled, 4-cycle diesel, 4-cylinder in line,
 Electronically controlled, high pressure common rail system, variable
 geometry turbocharger, air cooled intercooler, dual exhaust gas recirculation,
 DPD system with auto-regeneration.
 Emission certified _____ Tier IV Interim
 Displacement _____ 5.19 l
 Bore/Stroke _____ 115 x 125 mm
 Horsepower ISO 9249 (net) _____ 119 kW/160 hp at 1800 min⁻¹
 Maximum torque ISO 9249 (net) _____ 621 Nm at 1500 min⁻¹

HYDRAULIC SYSTEM

Type _____ 2 variable displacement axial piston pumps with regulating system
 Max oil flow _____ 2 x 211 l/min @ 1800 min⁻¹
 Working circuit pressure
 Boom/Arm/Bucket circuit _____ 34.3 MPa
 Boom/Arm/Bucket (with Power Boost) _____ 36.8 MPa
 Swing circuit _____ 29.4 MPa
 Travel circuit _____ 34.3 MPa

SWING

Maximum swing speed _____ 11.5 min⁻¹
 Swing torque _____ 64000 Nm

FILTERS

Suction filter _____ 105 µm
 Return filter _____ 6 µm
 Pilot line filter _____ 8 µm

WEIGHT

With 2.94 m Arm, 0.8 m³ bucket, 600 mm grouser shoe, operator, lubricant, coolant, full fuel tank and top guard OPG level 2

CX210C LC	WEIGHT (kg)	GROUND PRESSURE (MPa)
600 mm grouser shoe	21,600	0.045

TRAVEL

Travel motor _____ Variable displacement axial piston motor (automatic travel
 speed shifting)
 Max travel speed _____ 5.6 km/h
 Low travel speed _____ 3.4 km/h
 Gradeability _____ 70% (35°)
 Drawbar pull _____ 188 kN

ELECTRICAL SYSTEM

Circuit _____ 24V
 Alternator _____ 50 Amp
 Starter motor _____ 5.0 kW
 Battery _____ 2x12V 92 Ah/5HR

UNDERCARRIAGE

Number of carriers rollers (each side) _____ 2
 Number of track rollers (each side) _____ 8
 Number of shoes (each side) _____ 49
 Type of shoe _____ Triple grouser shoe

CAPACITIES

Fuel tank _____ 410 l
 Hydraulic system _____ 240 l
 Cooling system _____ 30.8 l
 Engine crank case _____ 23.1 l

C- SERIES

HYDRAULIC EXCAVATORS

CX250C

ENGINE

Model _____ ISUZU AL-4HK1X
 Type _____ Water-cooled, 4-cycle diesel, 4-cylinder in line,
 Electronically controlled, high pressure common rail system, variable
 geometry turbocharger, air cooled intercooler, DPD system with auto-
 regeneration.
 Emission certified _____ Tier IV Interim
 Displacement _____ 5.19 l
 Bore/Stroke _____ 115 x 125 mm
 Horsepower ISO 9249 (net) _____ 132 kw @ 2000 min⁻¹
 Maximum torque ISO 9249 (net) _____ 621 Nm @ 1800 min⁻¹

HYDRAULIC SYSTEM

Max oil flow _____ 2 x 234 l/min @ 2000 min⁻¹
 Boom/Arm/Bucket circuit _____ 34.3 MPa
 Boom/Arm/Bucket circuit (with Power Boost) _____ 36.8 MPa
 Swing circuit _____ 27/28.9 MPa
 Travel circuit _____ 34.3 MPa

SWING

Maximum swing speed _____ 10.6 rpm
 Swing torque _____ 74900 Nm

FILTERS

Suction filter _____ 105 µm
 Return filter _____ 6 µm
 Pilot line filter _____ 8 µm

WEIGHT

With 3.00 m Arm, 1.0 m³ bucket, 600 mm grouser shoe, operator, lubricant, coolant, full fuel tank and top guard OPG level 2

CX250C LC	WEIGHT (kg)	GROUND PRESSURE (MPa)
600 mm grouser shoe	25,100	0.050

TRAVEL

Travel motor _____ Variable displacement axial piston motor, automatic travel
 speed shifting
 Max travel speed _____ 5.5 km/h
 Low travel speed _____ 3.5 km/h
 Gradeability _____ 70% (35°)
 Drawbar pull _____ 201 kN

ELECTRICAL SYSTEM

Circuit _____ 24V
 Alternator _____ 50 Amp
 Starter motor _____ 5.0 kW
 Battery _____ 2x12V 92 Ah/5HR

UNDERCARRIAGE

Number of carriers rollers (each side) _____ 2
 Number of track rollers (each side) _____ 9
 Number of shoes (each side) _____ 51
 Type of shoe _____ Triple grouser shoe

CAPACITIES

Fuel tank _____ 410 l
 Hydraulic system _____ 250 l
 Cooling system _____ 30.2 l
 Engine crank case _____ 29.6 l

SPECIFICATIONS

CX210C LC

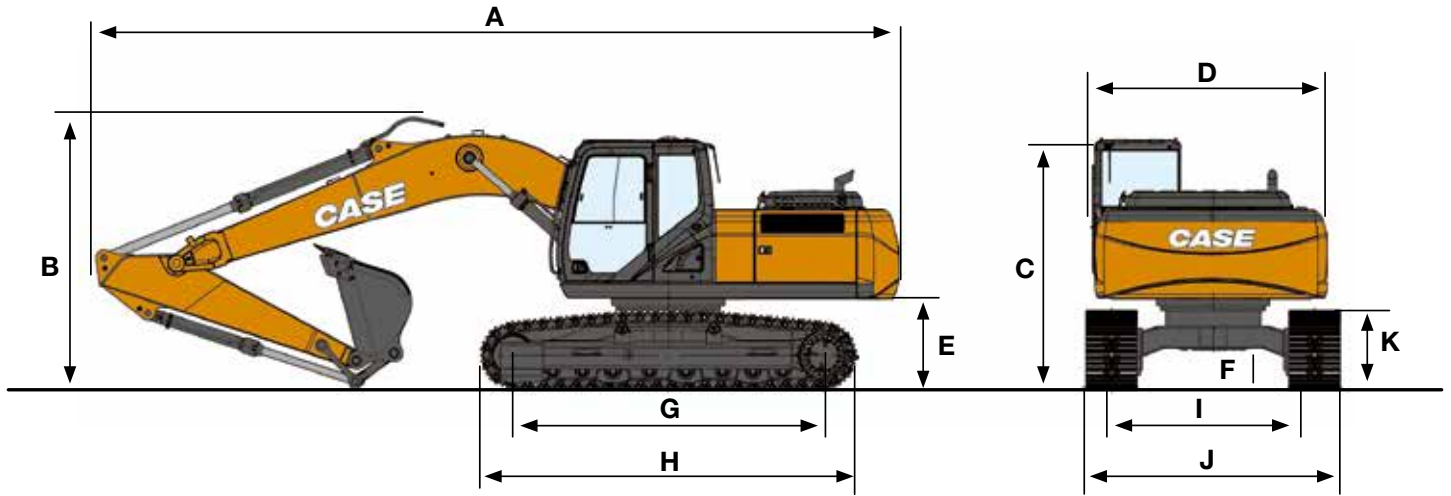

GENERAL DIMENSIONS

		Arm 2.94 m
	Overall length (without attachment)	mm 4960
A	Overall length (with attachment)	mm 9380
B	Overall height (with attachment)	mm 3070
C	Cab height	mm 3070
D	Upper structure overall width	mm 2770
	Swing (rear end) radius)	mm 2750
E	Clearance height under upper structure	mm 1040
F	Minimum ground clearance	mm 440
G	Wheel base (Center to center of wheels)	mm 3660
H	Crawler overall length	mm 4470
K	Crawler tracks height	mm 920
I	Track gauge	mm 2390
J	Undercarriage overall width (with 600 mm shoes)	mm 2990

PERFORMANCE DATA

		Arm 2.94 m
	Boom length	mm 5700
	Bucket radius	mm 1450
	Bucket wrist action	° 177
A	Maximum reach at GRP	mm 9730
B	Maximum reach	mm 9900
C	Max. digging depth	mm 6650
D	Max. digging height	mm 9610
E	Max. dumping height	mm 6810
	Arm digging force	kN 103
	Arm digging force with Power Boost	kN 110
	Bucket digging force	kN 142
	Bucket digging force with Power Boost	kN 152

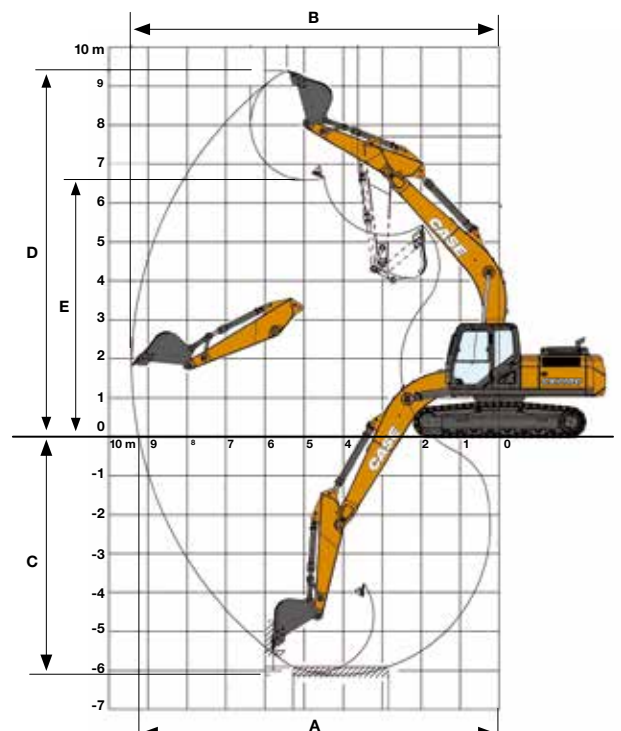

C- SERIES HYDRAULIC EXCAVATORS

CX250C LC

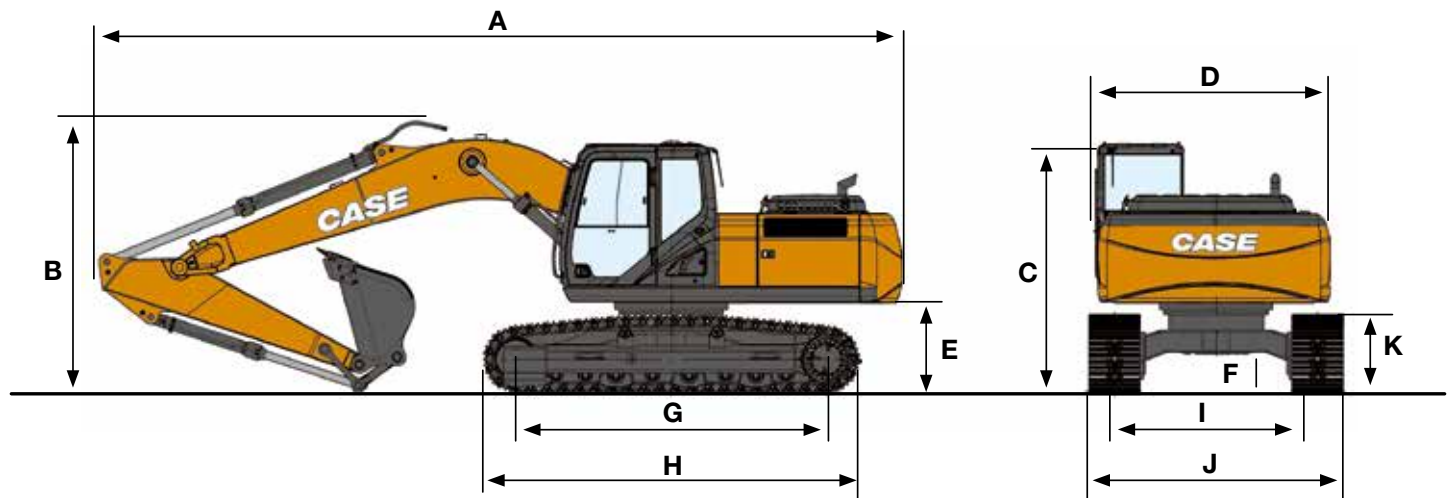

GENERAL DIMENSIONS

		Arm 3.00 m
	Overall length (without attachment)	mm 5270
A	Overall length (with attachment)	mm 9880
B	Overall height (with attachment)	mm 3200
C	Cab height	mm 3130
D	Upper structure overall width	mm 2770
E	Clearance height under upper structure	mm 1100
F	Minimum ground clearance	mm 460
G	Wheel base (Center to center of wheels)	mm 3840
H	Crawler overall length	mm 4650
K	Crawler tracks height	mm 940
I	Track gauge	mm 2590
J	Undercarriage overall width (with 600 mm shoes)	mm 3190

PERFORMANCE DATA

		Arm 3.0 m
	Boom length	mm 5850
	Bucket radius	mm 1570
	Bucket wrist action	° 175
A	Maximum reach at GRP	mm 10100
B	Maximum reach	mm 10280
C	Max. digging depth	mm 6900
D	Max. digging height	mm 9760
E	Max. dumping height	mm 6760
	Arm digging force	kN 120
	Arm digging force with Power Boost	kN 129
	Bucket digging force	kN 162
	Bucket digging force with Power Boost	kN 174

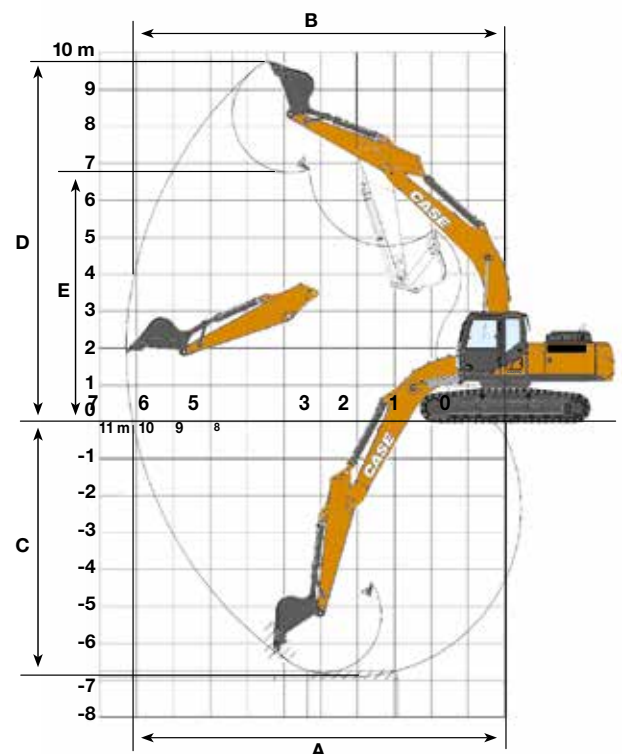

LIFTING CAPACITY

Front 360°	REACH							m
	1.5 m	3.0 m	4.5 m	6.0 m	7.5 m	9.0 m	At max reach	

CX210C Standard arm 2.94 m, 0.80 m³ bucket (650 kg) bucket, 600 mm shoes, max reach 9.90 m

7.5 m									2970*	2970*			2190*	2190*	7,76		
6.0 m									3790*	3500			2080*	2080*	8,71		
4.5 m									4630*	4630*	4290*	3380	3140*	2370	2070*	2070*	9,28
3.0 m									5690*	4720	4760*	3230	3640	2300	2140*	2040	9,54
1.5 m	6960*	6960*	9250*	9250*	9160*	6890	6620*	4410	4840	3070	3550	2220	2280*	1990	9,53		
0 m	9520*	9520*	8340*	8340*	10170*	6440	6710	4170	4690	2930	3490	2160	2520*	2050	9,28		
-1.5 m	13390*	13390*	10500*	10500*	10360*	6290	6560	4030	4610	2860			2940*	2240	8,77		
-3.0 m			14210*	12790	10090*	6360	6590	4080	4690	2930			3700*	2650	7,95		
-4.5 m			13170*	12830	9040*	6580	6490*	4320					5220*	3450	6,79		
-6.0 m					6160*	6160*							5840*	5840*	4,66		

CX250C Standard arm 3 m, 1.0 m³ bucket (790 kg) bucket, 600 mm shoes, max reach 9.90 m

9.0 m															2120*	2120*	7,57
7.5 m															1890*	1890*	8,85
6.0 m															1790*	1790*	9,68
4.5 m															1770*	1770*	10,18
3.0 m															1810*	1810*	10,41
1.5 m															1910*	1910*	10,4
0 m	4270*	4270*	9700*	9700*	12710*	8590	8580	5500	5950	3860	4410	2840	2100*	2100*	10,16		
-1.5 m	7650*	7650*	11290*	11290*	13240*	8290	8330	5290	5810	3730	4350	2780	2400*	2400*	9,68		
-3.0 m	9810*	9810*	14490*	14490*	13060*	8310	8300	5270	5810	3740			2900*	2840	8,94		
-4.5 m	14320*	14320*	17920*	17210	12140*	8490	8390	5420	5930	3910			3860*	3550	7,86		
-6.0 m			14120*	14120*	9730*	8720	6580*	5620					5760*	5150	6,3		

* Lift capacities are taken in accordance with SAE J1097 / ISO 10567 / DIN 15019-2

Lift capacities shown in kg do not exceed 75% of the tipping load or 87% of the hydraulic lift capacity

Capacities that are marked with an asterisk (*) are hydraulic limited

If the machine is equipped with a quick coupler, subtract the weight of the quick coupler from the load shown in the table to calculate the real lift capacity

STANDARD EQUIPMENT

ENGINE

Isuzu 4-cylinder turbo-charged diesel
Tier IV Interim
Electronic fuel injection
High pressure common rail system
Neutral safety start
Auto-engine warm up, emergency stop
Glow-plug pre-heat
EPF (Engine Protection Feature)
Dual-stage fuel filtration
Dual element air filter
Remote oil filter
Green plug oil drain
500-hour engine oil change interval
24-Volt system
Battery disconnect switch
High ambient temperature cooling package
Fuel cooler
Fuel filter restriction indicator
Idle start
Radiator, oil cooler, intercooler
Refueling Pump
FUEL ECONOMY SYSTEMS
Engine Idle/Fuel Economy System:
Auto-idle
One-touch idle
Auto-idle shut-down
Torque control
Boom Economy Control (BEC)

Swing Relief Control (SWC)
Spool Stroke Control (SSC)
HYDRAULICS
Auto power boost
Auto travel speed change
Selectable work modes
Pre-set auxiliary pump settings
Switch controlled auxiliary selection
Hydraulic filter restriction indicator
Oil cooler
5,000 hour hydraulic oil change interval
2,000 hour hydraulic filter change interval
UPPERSTRUCTURE
ISO mirrors
Handrail – RH access
ISO guard rails
Isolation mounted cab (4 point fluid mounting)
Lifting eyes for counterweight
Lockable fuel cap, service doors and toolbox
Rear and side view safety camera
UNDERCARRIAGE
600 mm steel triple grouser shoes
LC type (Long Carriage) undercarriage
Sealed link chain
Travel alarm
ATTACHMENTS
HD Monoboam
HD Arm
HD bucket linkage

Boom mounted work light
Auxiliary pipe brackets
Centralized lube bank
Attachment cushion valve
OPERATOR STATION
Pressurized cab
Safety glasses for all windows
Sun visor&rain deflector
AC/heat/defrost w/auto climate control
Hot&coolbox, cup holder & ashtray
Cloth covered air-suspension seat fully adjustable and reclinable
Adjustable armrests
Tilting consoles - 4-position
Low-effort joystick controls
Sliding cockpit
Auxiliary select system
Multifunction LCD color monitor
Anti-theft system (start code system)
Rubber floor mat
12 V electric socket /24 Vcigarette lighter
One-piece right hand window
Internal & external view mirrors
Working lights (boom&upperstructure)
Cab top working lights
Windshield wiper / washer
Storage compartments
On-board diagnostic system

OPTIONAL EQUIPMENT

HYDRAULICS

Clamshell circuit/Low-flow circuit
Single/Double acting multifunction auxiliary circuit - pedal activated (hammer/high flow)
Single acting pedal activated hammer circuit

ATTACHMENTS

Hydraulic quick coupler provision
Safety valves and HD bucket linkage with hook
Overload warning device
UNDERCARRIAGE
700 / 800 mm steel shoes
OPERATOR STATION

FOPS level II
Front cab guard - vertical bars (OPG level 2)
Front cab guard - vertical bars (OPG level 1)
Front mesh screen
AM/FM CD/radio with antenna and 2-speakers



PARTS AND SERVICE

Wide network of customer support across the world.

No matter where you work, we're here to support and protect your investment and exceed your expectations. You can count on Case and your Case dealer for full-service solutions-productive equipment, expert advice, flexible financing, genuine Case parts and fast service. We're here to provide you with the ultimate ownership experience. To locate a Case dealer or learn more about Case equipment or customer service, go to www.casece.com

NOTE: CASE provides specific outfits for various countries and many optional fittings (OPT). The illustrations on this or other leaflets may relate to standard or optional fittings. Please consult your CASE dealer for any information in this regard and any possible updating on components. CNH Industrial reserves the right to modify machine specifications without incurring any obligation relating to such changes.

